

BIO-FIGHTER®

Nomad & Nomad 2 Ultraviolet Light Systems

Installation & Operation Manual

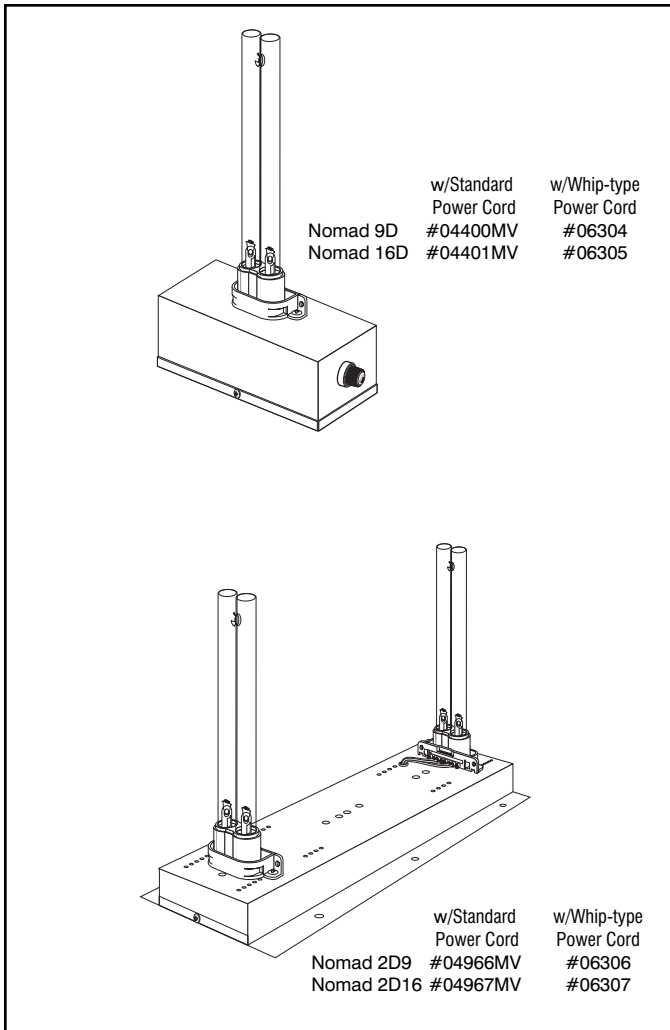

GENERAL

This product is designed to help disinfect the internal surfaces of heating, ventilation, and air conditioning systems. Bacteria and viruses that are in the air stream that passes through the system will also be reduced. The result is an improved level of indoor air quality for occupants and improved system hygiene.

The Bio-Fighter® emits ultraviolet(UV-C) radiation at a frequency of 254 nanometers, which has been proven effective in damaging the DNA of microorganisms such as viruses, bacteria, yeast and molds. This process either destroys the micro-organism or neutralizes its ability to reproduce.



FEATURES

- Reduces or prevents mold growth on HVAC coils, allowing them to operate at peak efficiency. Also significantly reduces bacteria, viruses, fungi, and yeasts in the ductwork.
- High output, long life UV-C lamps.
- Low maintenance and reduced costs.
- Multi-voltage electronic ballast.

INCLUDED INSIDE BOX

- Germicidal ultraviolet light system
- UV lamp(s)
- Mounting brackets (Nomad only)
- 3/8" mounting screws (Nomad only)
- 1" mounting screws
- 1.5" mounting screws (Nomad 2 only)
- Mounting spacers (Nomad 2 only)
- Viewport(s)
- Installation & operation manual
- UV-C warning label for duct
- Registration card

TOOLS REQUIRED FOR INSTALLATION

- Electric drill
- Phillips screw bit or screwdriver
- 1/2" drill bit
- 3" Holecutter (Insert-mount installation only)
- Eye protection

BEFORE INSTALLING

- Read all instructions carefully. Failure to do so could damage the equipment or cause harm to yourself or others.
- Acknowledge all warnings.
- Only qualified technicians should perform the installation.

SPECIFICATIONS

Base Dimensions

MODEL	DIM. A	DIM. B	DIM. C	DIM. D
Nomad 9D	3.125"	7"	3.5"	9"
Nomad 16D	3.125"	7"	3.5"	16"
Nomad 2D9	1.5"	17"	5.93"	9"
Nomad 2D16	1.5"	17"	5.93"	16"

Weight:

Nomad 9D - 2 1/4 lbs.

Nomad 16D - 3 3/4 lbs.

Nomad 2D9 - 5 1/3 lbs.

Nomad 2D16 - 7 5/8 lbs.

Electrical:

120V-240V, 50/60Hz, 1PH. 3 amp-250v fuse.

Operating Environment:

45° F - 150° F (Outside of duct.)

Accessories:

Remote safety interlock (#06150).

Listings:

FIFRA - File #73316

(Federal Insecticide Fungicide Rodenticide Act)

ETL Safety Agency - File #2002554

Specifications subject to change without notice.

NOMAD

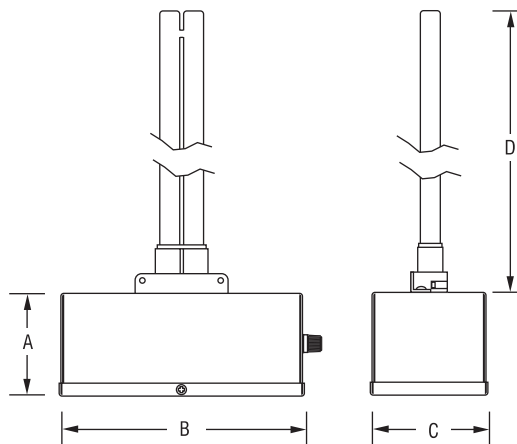

NOMAD 2

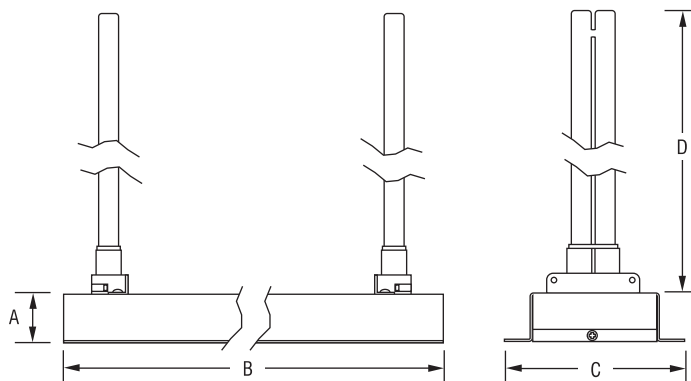

ETL LISTED
 CONFORMS TO
 UL STD 1598
 CERTIFIED TO
 CSA STD C22.2 NO. 250.0

IMPORTANT:

The device must be installed in compliance with all national and local electrical and mechanical codes. Failure to do so will void ETL safety listing and Dust Free® warranty.

Nomad/Nomad 2 Mounting Options (Fig.1)

The Nomad/Nomad 2 may be installed as a parallel mount, perpendicular mount, or as an insert mount depending on your requirements. The included brackets and screws allow the device to be mounted in any of these orientations.

Note: For insert-mount applications a 3" hole must be cut into the duct to allow for the insertion of the lamp and connector.

Perpendicular Mount

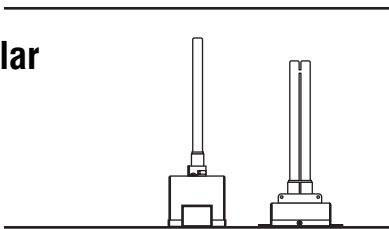

Parallel Mount

(Nomad Only)

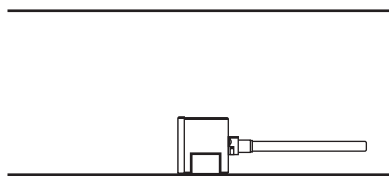

Insert Mount

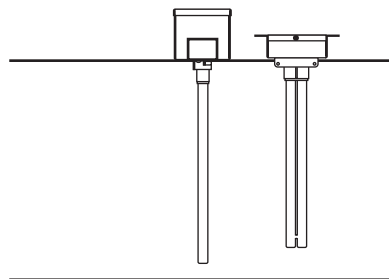

Fig. 1 Device may be mounted in a variety of orientations.

Attach Mounting Brackets (Nomad Only)(Fig.2)

Attach brackets to the side of the Nomad chassis with the 3/8" mounting screws. Choose the set of bracket holes appropriate for your installation. Be sure bracket is flush then install the Nomad inside the HVAC system in the desired location and orientation.

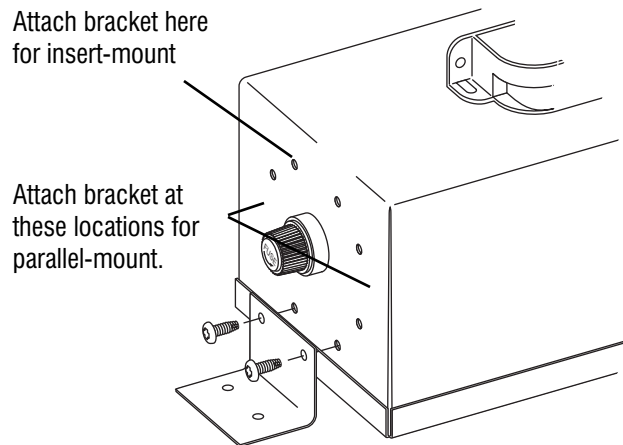

Fig. 2 Mount the brackets to the Nomad using the 3/8" mounting screws. Illustration shows perpendicular mounting.

SPECIAL INSTALLATION NOTES

- Do not install in closet return grille applications.
- Do not install in outdoor applications.
- Do not expose wiring or plastic parts to UV-C light.
- Do not install beneath a humidifier.

⚠ CAUTION

Sharp Edge Hazard.

Be careful of sharp edges on device and HVAC equipment while installing the device. Personal injury may result.

INSTALLING THE NOMAD

Perpendicular/Parallel Mount (Fig.3)

With the brackets attached, place the Nomad at the desired installation location/orientation and secure the brackets to the duct using the 1" mounting screws.

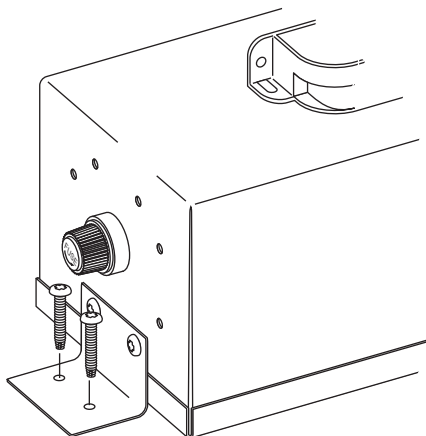

Fig. 3 Mount the Nomad to the duct using the 1" mounting screws.

Insert Mount

If installing the Nomad as an insert-mount:

1. Make a 3" diameter lamp hole in the duct.
2. Install lamp as shown on page 5.
3. Insert the Nomad lamp through the holes and secure brackets to the duct using the provided 1" mounting screws.

ADJUSTING THE LAMPS (Nomad 2 Only)

The Nomad 2 may have its lamp centers adjusted over a range of 7"-17.5" to fit your application. The Nomad 2 comes from the factory with its lamps set at 14.5" centers.

To adjust lamp centers remove the screws securing the lamp to the chassis and reposition in any of the adjustment holes. If shortening the centers from the factory setting, the lamps will have to be pivoted around to the inside set of adjustment holes to clear the lamp wires.

INSTALLING THE NOMAD 2

Perpendicular Mount (Fig.4)

Place the Nomad 2 at the desired installation location/orientation and secure to duct with the included 1" mounting screws.

Optional spacers are provided to help prevent "sweating" where insulation is compacted. When using spacers use the 1.5" mounting screws included with the Nomad 2.

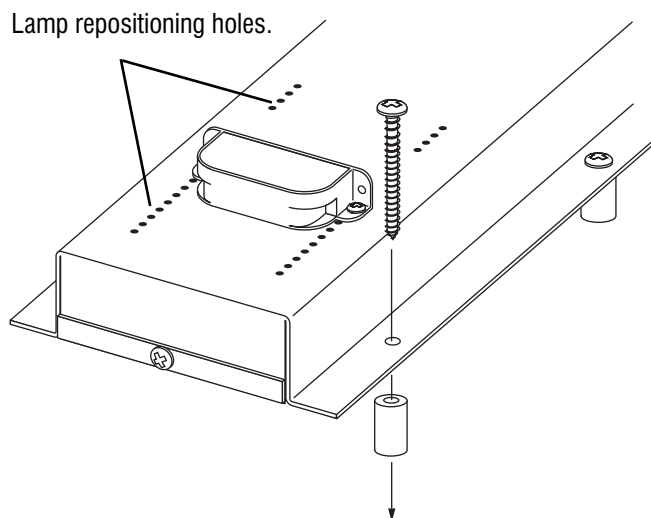

Fig. 4 Mount the Nomad to the duct using the 1" mounting screws.

Insert Mount

If installing the Nomad 2 as an insert-mount:

1. Make two 3" diameter lamp holes in the ductwork.
2. Install lamps as shown on page 5.
3. Remove the retaining screws and bottom cover of the Nomad 2.
4. Insert the Nomad 2 lamps through the holes and secure chassis to duct using the provided 1" mounting screws. Any of the holes in the cover may be used for mounting.

⚠ CAUTION

Sharp Edge Hazard.

Be careful of sharp edges on device and HVAC equipment while installing the device. Personal injury may result.

INSTALLING THE LAMP (Fig. 5)

To maximize the efficiency and life of the UV-C lamp, clean each lamp prior to installation. Use isopropyl alcohol and cotton cloth to wipe dust and fingerprints from the lamp.

Attach lamp to connector by inserting the front of the lamp into the connector first then gently snap the back of the lamp in place.

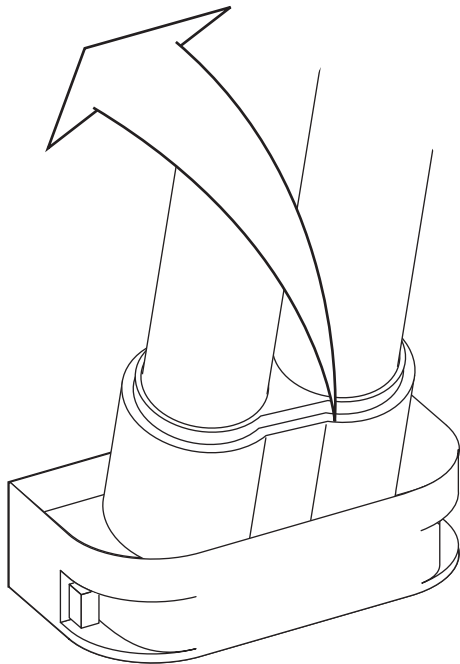

Fig. 5 Attach lamp to connector by inserting the front of the lamp first then snapping the back of the lamp into place.

⚠ WARNING

UV-C Light Hazard.
 UV-C light can cause temporary or permanent loss of vision, and sunburn. Take precautions to protect eyes and skin from direct exposure.

⚠ WARNING

Mercury Hazard. Do Not Break.
 Each UV-C lamp contains a small amount of Mercury. May cause redness or irritation. Use proper disposal techniques in case of breakage. See page 6.

⚠ CAUTION

Clean lamp(s) prior to installation.
 Failure to remove dirt and fingerprints from the lamp(s) could shorten their lifespan.

INSTALLING THE VIEWPORT

The Nomad/Nomad 2 comes with a UV-C safe viewport(s) that must be installed separately. To install the viewport, select a location near the Nomad/Nomad 2 installation and drill a 1/2" hole in the duct. Then press the viewport into the hole. For a Nomad 2 installation, make sure each viewport is positioned near each lamp location.

CONNECTING TO POWER

With the Nomad/Nomad 2 installed, connect power cord to proper power. If installing model with whip-type power cord see Fig. 6 below for power connection. Use the viewport to verify lamp operation. A blue light should be seen.

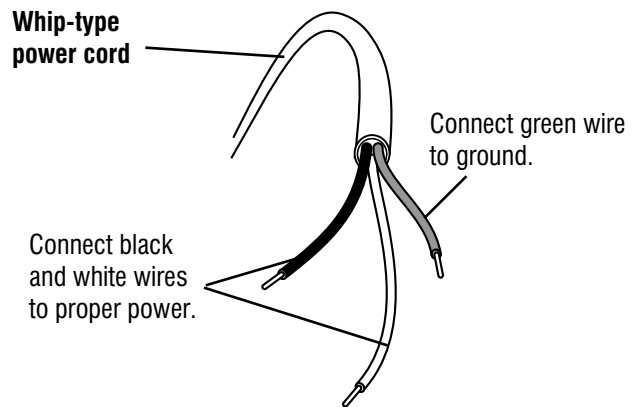

Fig. 6 Power connection for models with whip-type power cord.

OPERATION

The Nomad/Nomad 2 should be operated continuously to extend the life of the lamp(s), and to increase the effectiveness in disinfecting the location selected.

INSTALL REMOTE DOOR INTERLOCK SWITCH

(Optional accessory #06150.)

Mount the remote door interlock switch so that power to the device is automatically disconnected anytime the air handler access panel is opened.

1. Remove the black remote interlock hole cap from the side of the Nomad/Nomad 2.
2. Insert remote door interlock switch wire through hole. Secure with strain relief. Install male and female connector to remote door interlock switch

INSTALL REMOTE INTERLOCK SWITCH (cont'd)

wires and connect to UV-C light.

3. Mount remote door interlock switch and actuator to access panel opening.
4. Check operation. Device should turn off when access panel is opened.

Note: Remote door interlock switch includes 5 ft(1.5m) 120V power cord with custom connectors. If device is installed more than 5 ft(1.5m) away from remote door interlock switch, field wiring will be required in accordance with national and local codes.

IF THE LAMP DOES NOT ILLUMINATE

- Check that the lamp connector is securely attached to lamp.
- Check that the fuse is in good working order. Replace if necessary.
- Check that proper power is being supplied to the device, and that switch lights when turned on.

LAMP REPLACEMENT(Annually)

The lamp should be replaced annually even if it appears to be operating normally. UV-C energy production diminishes over time.

1. Obtain the correct replacement lamp for your model.
2. Disconnect power to the equipment. *Allow lamp to cool 10 minutes before touching.*
3. Remove old lamp and install new lamp. See page 5.
4. Reconnect power. For Nomad 2 make sure power switch is in the "ON" position.
5. Use viewport to verify operation.

⚠ WARNING

Burn Hazard.

During replacement, allow lamps to cool 10 minutes before removing them. Personal injury may result.

⚠ WARNING

Mercury Hazard. Do Not Break.

Each UV-C lamp contains a small amount of Mercury. May cause redness or irritation. Use proper disposal techniques in case of breakage.

FUSE REPLACEMENT

1. Disconnect power.
2. Unscrew the knob marked "Fuse" and remove fuse.
3. Install new fuse and screw knob back in place. Only use a 250V/3 amp fuse.
4. Reconnect power.

LAMP DISPOSAL

Dispose of your spent UV-C lamps at your local recycling center. You may also send your spent lamps in the same container you received your replacement lamps to:

Dust Free® Lamp Reclamation
1112 Industrial Park Drive
Royse City, TX 75189

PROPER CLEAN-UP TECHNIQUE IN CASE OF LAMP BREAKAGE

- Wear protective gloves, eyewear and mask.
- Sweep the broken glass and debris into a plastic bag, seal the bag, and dispose of properly. Contact your local waste management office for proper disposal.
- **Do not use a vacuum cleaner. Do not incinerate.**

Replacement Parts	Part No.
UV-C Lamp - 9"	06035
UV-C Lamp - 16"	06036
Ballast - 9"	06149
Ballast - 16"	06167
Remote Safety Interlock	06150
Fuseholder	212225-00
Fuse	750-0108-001
Lighted On/Off Switch	750-0026-001

For information on the dealer in your area call: 1-972-635-9564.
 Visit us at <http://www.dustfree.com>

LIMITED LIFETIME WARRANTY

Dust Free Inc. warrants this Bio-Fighter UV Light to be free from defects in materials and workmanship under normal use and service, for as long as it is owned by the original purchaser. This warranty does not cover UV-C lamp(s), which carry a one (1) year warranty from the date of installation, or the ballast(s) which carry(s) a three (3) year warranty.

This warranty does not cover cosmetic damage, damage due to acts of God, damage as a result of handling or shipment, negligence, misuse, connection to improper voltage, improper maintenance, or abuse. This warranty is void if defect(s) result from failure to have this unit installed by a qualified, properly licensed, heating and air conditioning contractor in compliance with all local building and construction codes.

Dust Free Inc.'s exclusive obligation under this warranty shall be to supply, without charge, a replacement for any covered component of the Bio-Fighter UV Light which is found to be defective within the parameters defined herein. Dust Free Inc. reserves the right to replace or repair the defective part or component.

DUST FREE INC. SHALL NOT BE LIABLE FOR ANY LOSS OR DAMAGE OF ANY KIND, INCLUDING ANY INCIDENTAL OR CONSEQUENTIAL DAMAGES RESULTING, DIRECTLY OR INDIRECTLY, FROM ANY BREACH OF WARRANTY, EXPRESS OR IMPLIED, OR ANY OTHER FAILURE OF THIS PRODUCT. (Some states do not allow the exclusion or limitation of incidental or consequential damages, so this limitation may not apply to you.) THE WARRANTIES SET FORTH HEREIN ARE EXCLUSIVE AND DUST FREE INC. EXPRESSLY DISCLAIMS ALL OTHER WARRANTIES, WHETHER WRITTEN OR ORAL, IMPLIED OR STATUTORY, INCLUDING BUT NOT LIMITED TO ANY WARRANTIES OF MERCHANTABILITY, WORKMANSHIP, OR FITNESS FOR A PARTICULAR USE. If the limited warranty is void due to failure to use a qualified contractor all disclaimers of implied warranties shall be effective upon installation.

How to make a warranty claim or have questions answered:

Should you have a warranty claim or questions about the warranty policy, contact the distributor or dealer from which you purchased the product. Proof of original purchase and proof of identity that the original purchasing party is filing the claim is required in order to initiate a warranty claim. Defective parts must be returned no later than thirty (30) days after the failure to the installing contractor together with the model number, serial number, and date of installation. All service and removal must be performed by a licensed HVAC contractor. You must pay shipping charges and all other costs of warranty service. Warranty is only valid the United States and Canada.

THIS WARRANTY SHALL NOT OBLIGATE THE MANUFACTURER FOR ANY LABOR COSTS AND SHALL NOT APPLY TO DEFECTS IN WORKMANSHIP OR MATERIALS FURNISHED BY THE INSTALLING CONTRACTOR AS CONTRASTED TO DEFECTS IN THE GERMICIDAL LIGHT ITSELF.

NOTE: Do not return any products or parts to the factory without a factory issued Return Authorization number issued by the Dust Free Inc. customer service department.

In the event you have any questions concerning the use and care of this product or this warranty which have not been answered to your satisfaction by the distributor or dealer, please call or write the factory.

Dust Free, Inc
PO Box 519
1112 Industrial Park Drive
Royse City, TX 75189
1-972-635-9564